

Task 1 Cable with multiple loads

- a) Draw the corresponding subsystems and the force diagram for the given situation. Indicate the magnitude of the reaction forces and the maximum load in the table. Colour tensile forces red, compressive forces blue and external forces green.
- b) The cable can take a maximum load of $N_{d\max} = 70\text{kN}$. With the help of the force diagram, find the resulting form of the cable and draw it in the existing form diagram.

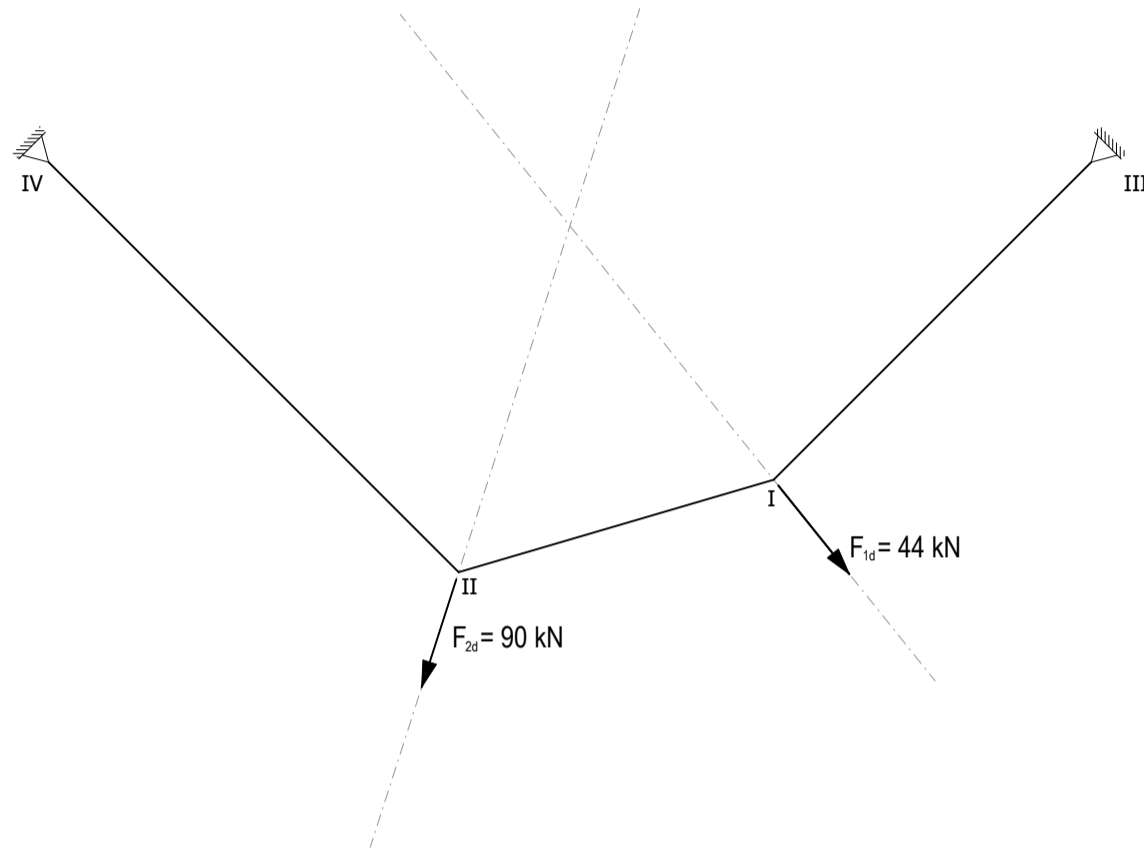

form diagram 1:50

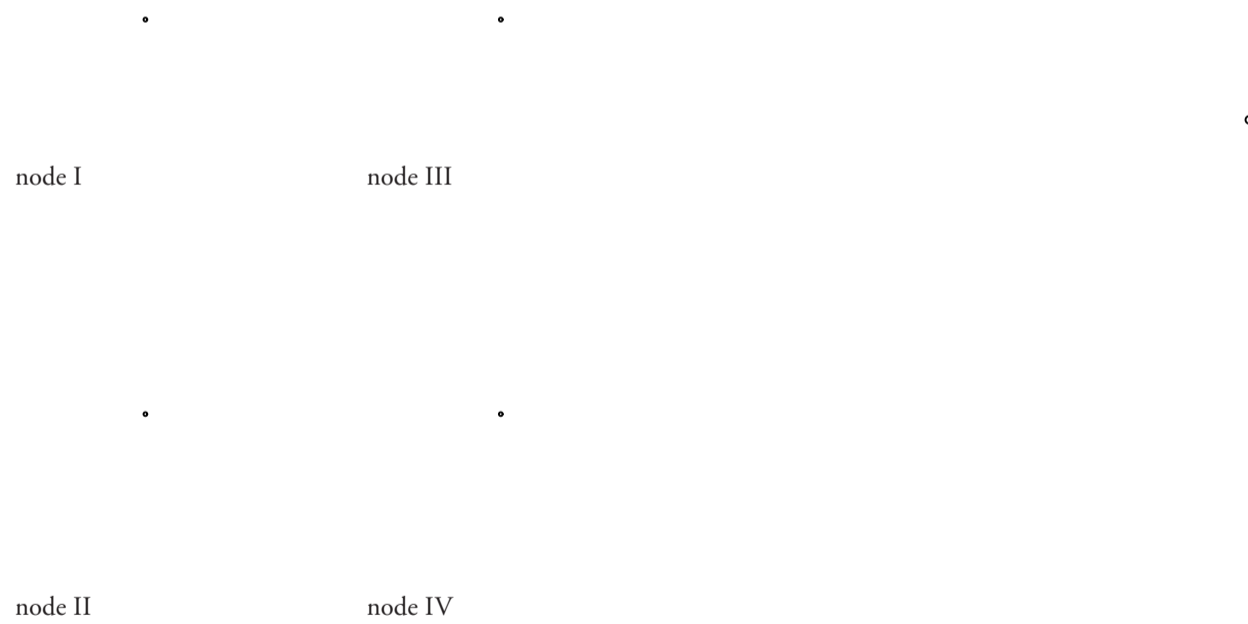

subsystem

| A [kN] | B [kN] | $N_{d\max}$ [kN] |
|-----------|-----------|---------------------|
| | | |

Task 2 Material properties

To get a feel for how different materials behave under tension and compression forces, we compare wood (spruce), steel (S235) and concrete (C20/25) in the following.

- Complete the table with values from the formula and your own calculations.
- Given is a tension load of $N_d = 12\text{kN}$. Calculate the required cross-sectional area A_{req} for the three materials. The cross-sectional area corresponds to a square solid profile. Calculate the side length a of the profile for each of the three materials and compare them. ($A_{\text{req}} = a^2$)
- Repeat b) but now with a compression load of $N_d = 12\text{kN}$.
- What do you notice when comparing the different cross-sections?
- Which material behaves the most brittle and which the most ductile when subjected to a tensile load? Consult the stress-strain diagrams in the lecture on “Material and Dimensioning”.

a)

| | Timber Spruce | Steel S235 | Concrete C20/25 |
|------------|------------------|---------------|--------------------|
| γ_M | | | |
| f_{tk} | | | |
| f_{td} | | | |
| f_{ck} | | | |
| f_{cd} | | | |

b) Wood

Steel

Concrete

c) Wood

Steel

Concrete

d)

e)

Task 3 Closing string

- a) The first situation shows three structures with different statical depth. Draw the corresponding force diagram for the three structures. Complete the form and force diagram with the closing string and find the intersection point *i* and the respective pole *o*. Colour tensile forces red, compression forces blue and external forces green.
- b) In the second situation, support B changes and with it the closing string. Proceed in the same way as in a).
- c) What do you find when comparing the different structural systems with regard to the closing string, the intersection point *i* and the pole *o*?

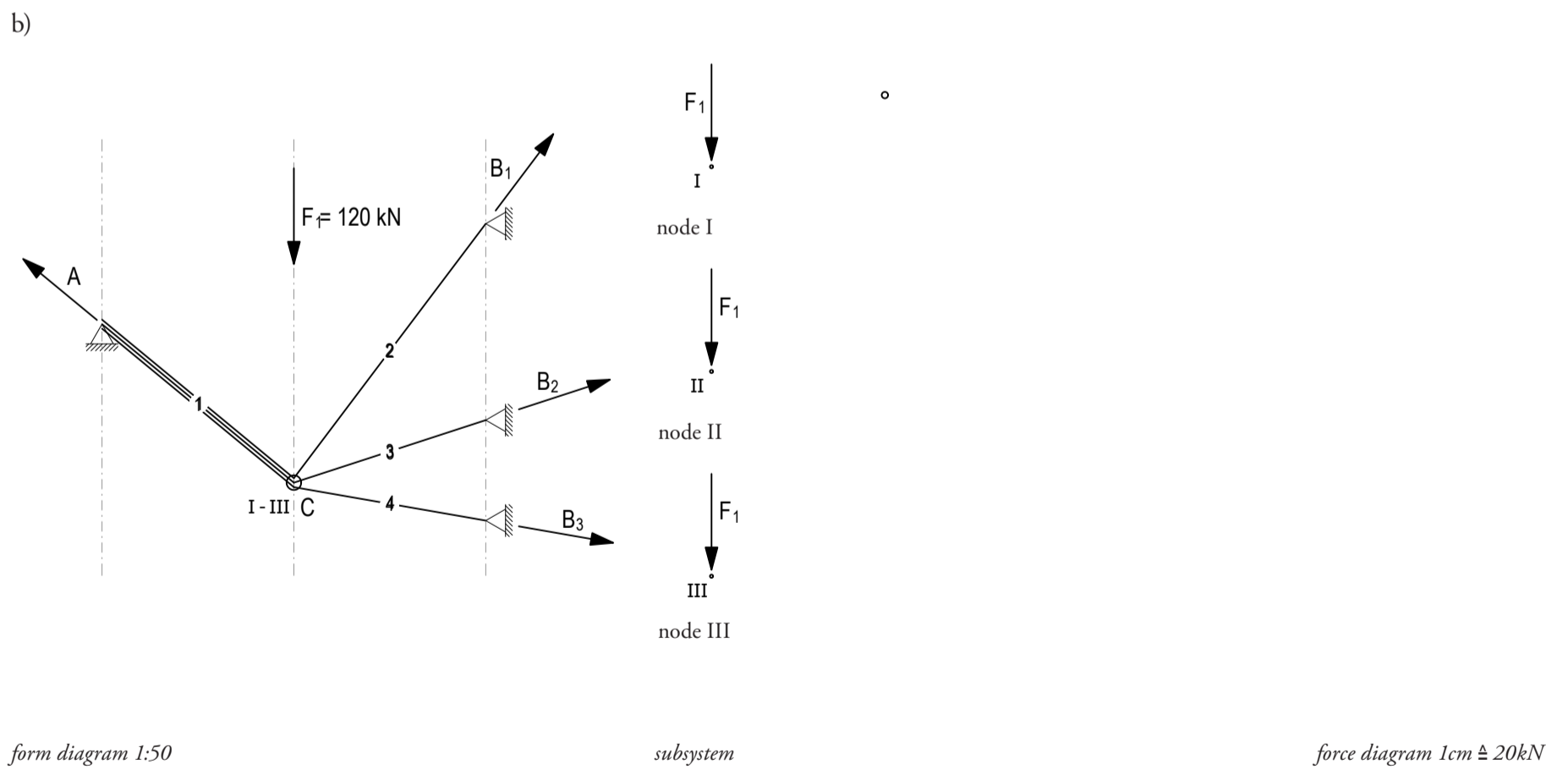
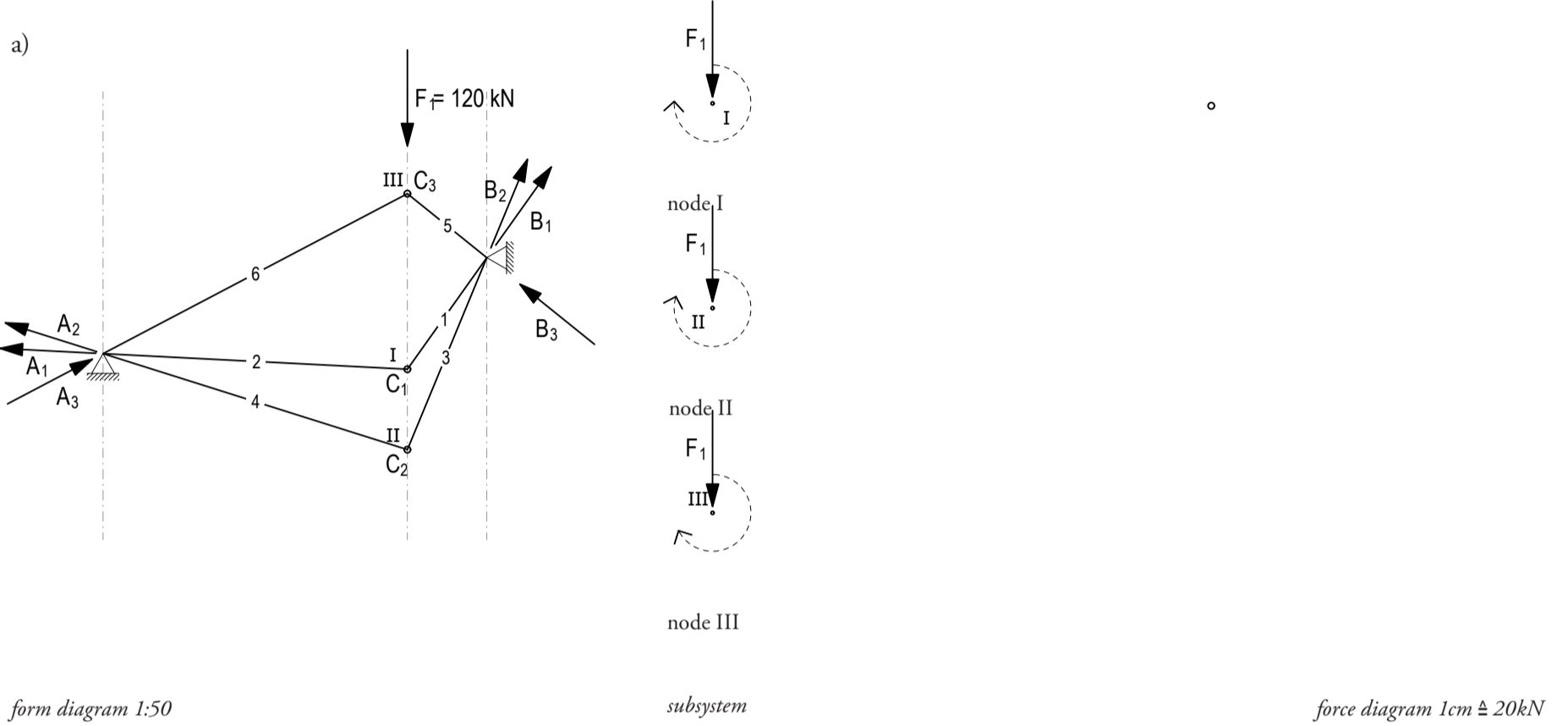

c) _____

Task 4 Funicular form

Design the form of a possible funicular cable for the cases a) to d) using the force diagram. Draw the tension forces in red, compression forces in blue and reaction forces in green.

a)

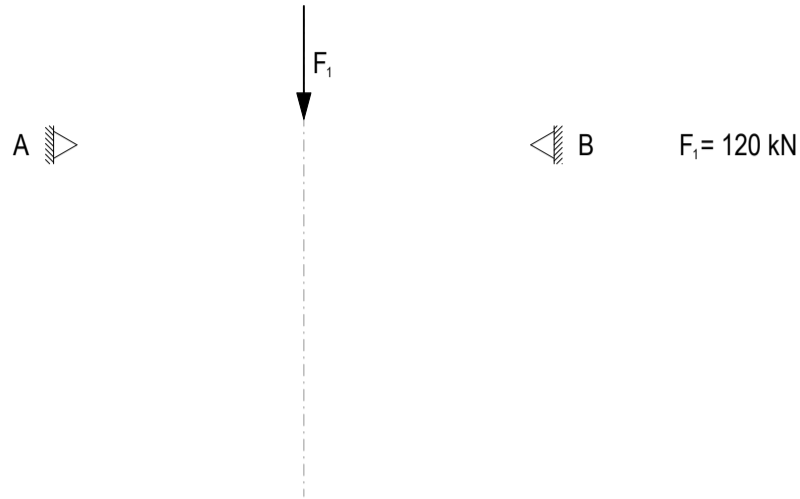

b)

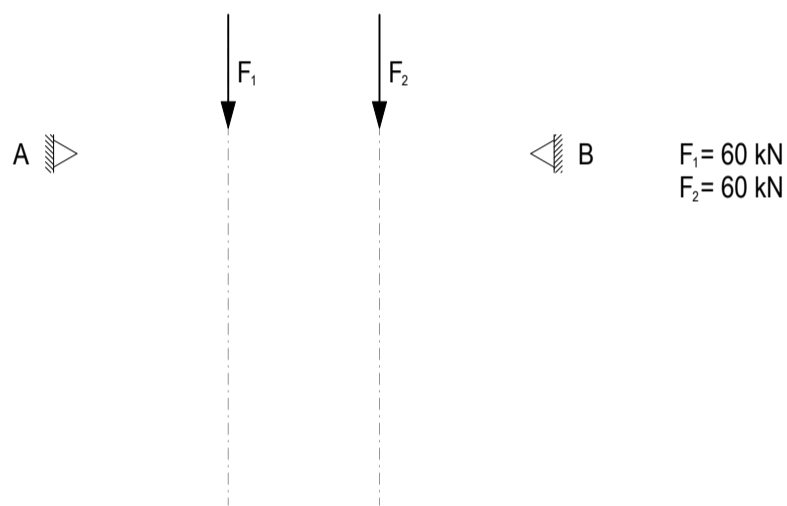

c)

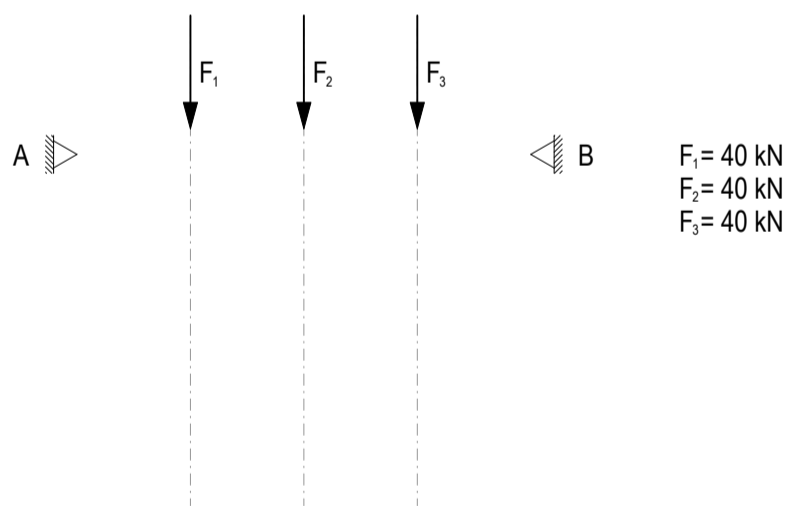

d)

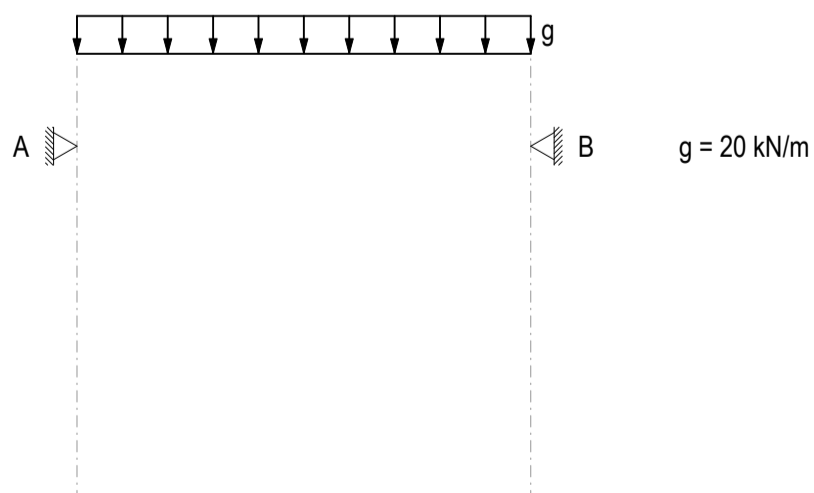

Task 5 Funicular form

For scenarios a) to d), find and draw the funicular form through the given point. Make use of the force diagram in c) and d). Draw the direction of the reaction force in the form diagram and mark tension forces with red and compression forces with blue.

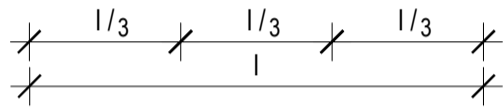
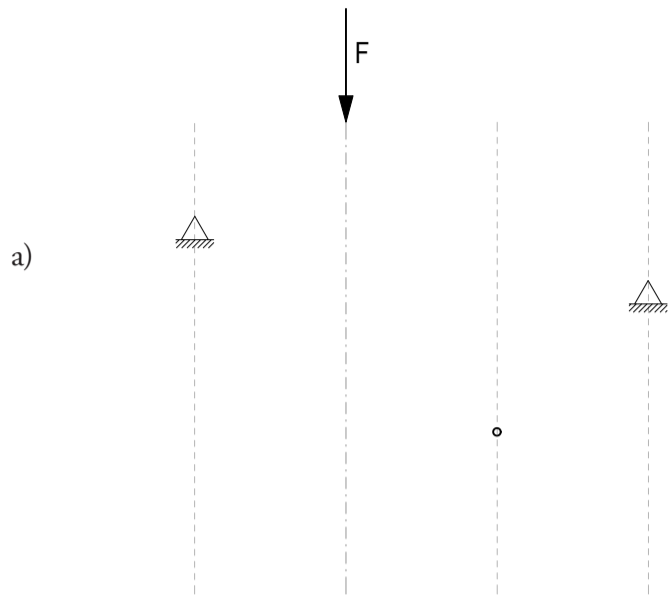

form diagram

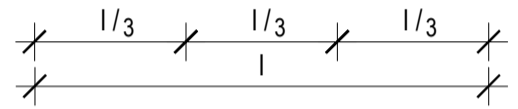
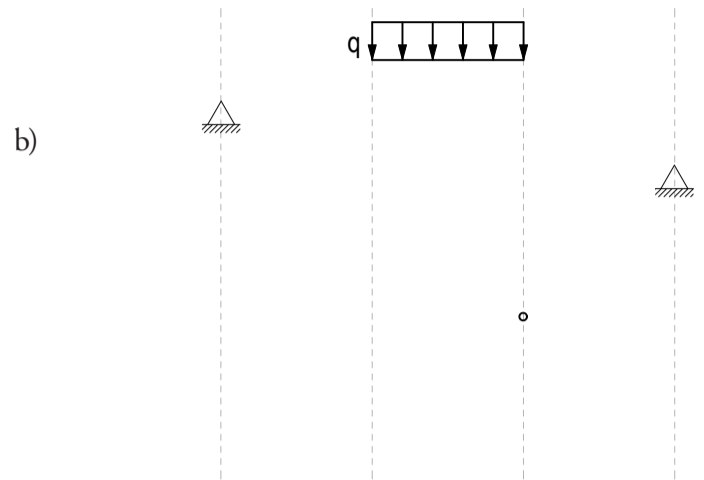

form diagram

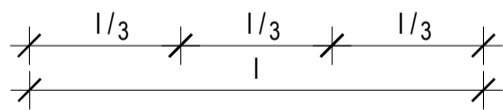
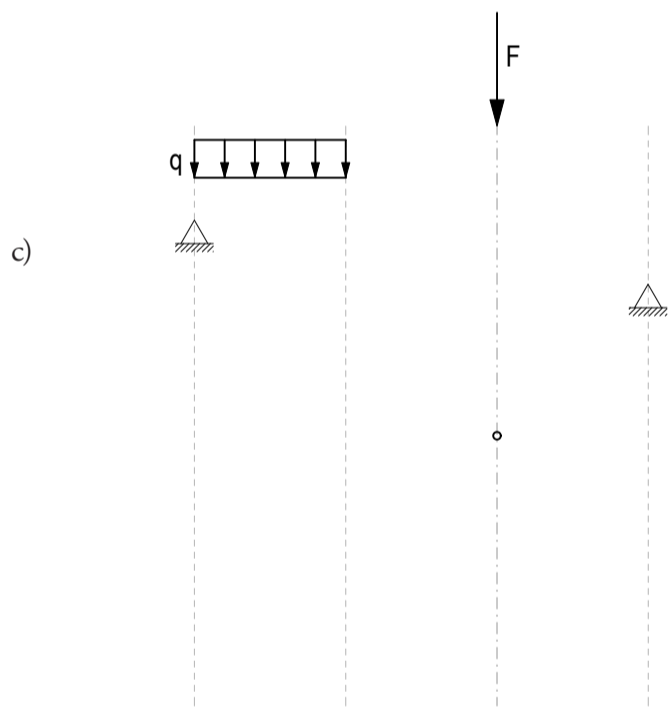

form diagram

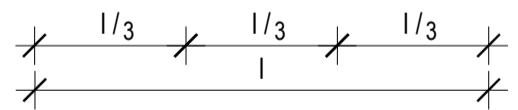
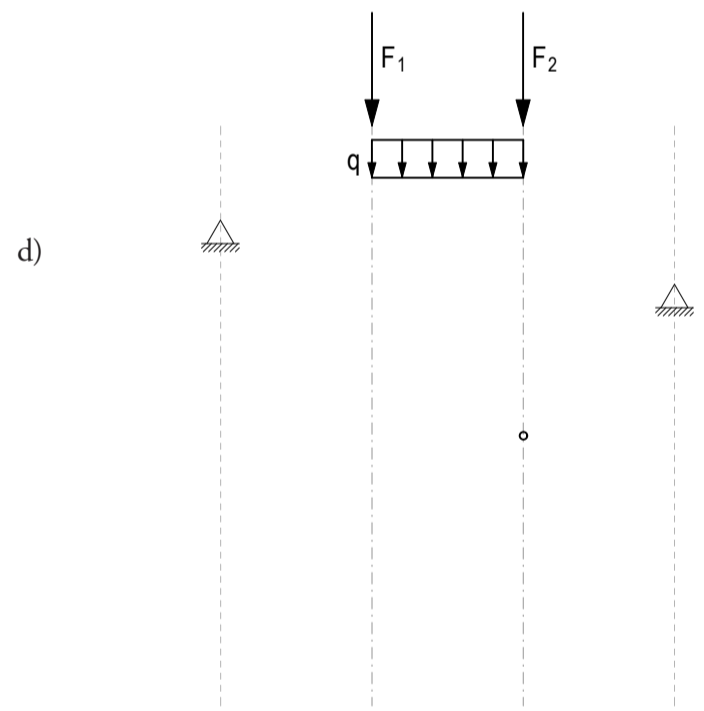

form diagram



force diagram

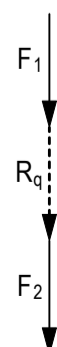

force diagram

Task 6 Designing a suspended roof

- a) For the situation below, determine the shape of the roof. The roof is fixed between the supports A and B. It is a hanging construction. The maximum cable force is $N_{d,max} = 3000$ kN. Draw the corresponding form and force diagrams. Draw the direction and determine the magnitude of the reaction force. Indicate tension forces with red and compression forces with blue.
- b) Calculate the diameter for the cable made of steel S235 due to the maximum cable force.

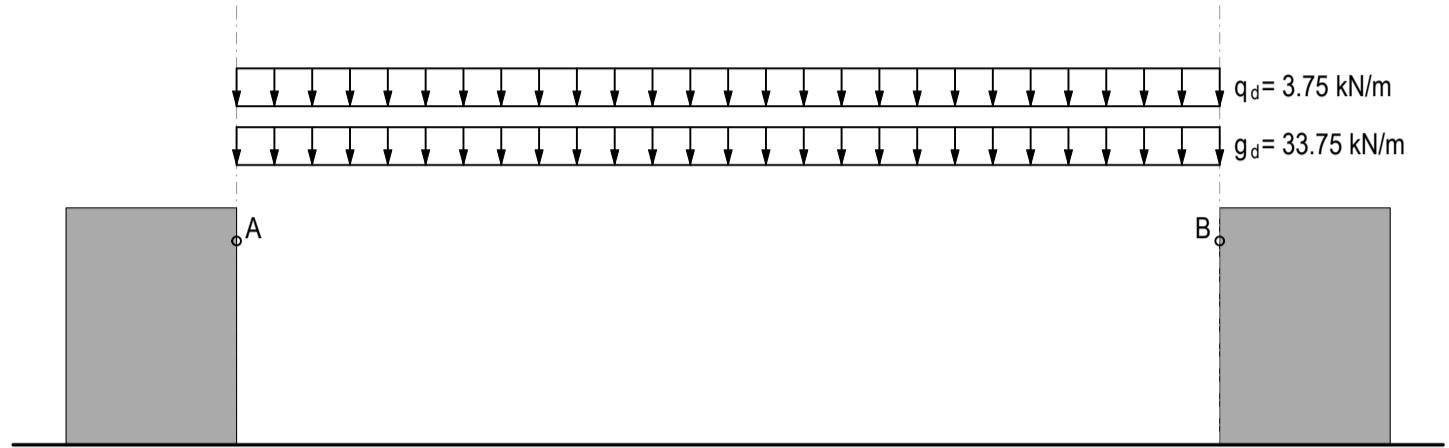

form diagram 1:500

| A [kN] | B [kN] |
|-----------|-----------|
| | |

force diagram 1cm ≙ 250kN

b)

Task 7 Suspension bridge Sigriswil

- Calculate the total line load s_d on the dimensioning level for one of the two main cables considering the safety factors. Then calculate the total resultant point load R . Assume the constant area load is $\bar{g}_k = 1.0 \text{ kN/m}^2$, and the live load is $\bar{q}_k = 0.7 \text{ kN/m}^2$.
- Find the maximum force in the cable, the support reaction forces and the forces in the pylons and backstays assuming that the main cable (top cable) represents a parabola. Mark tension forces in red, compression forces in blue and external forces in green.

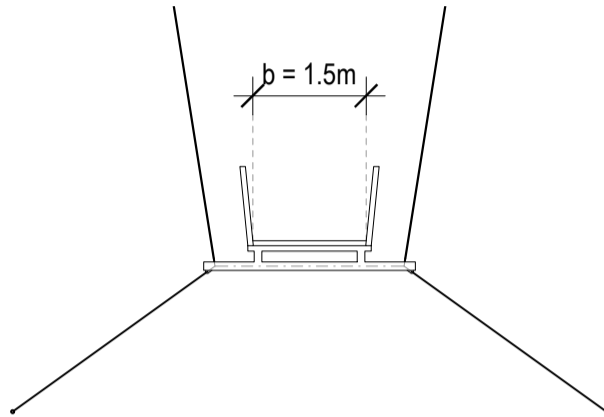

cross section 1:100

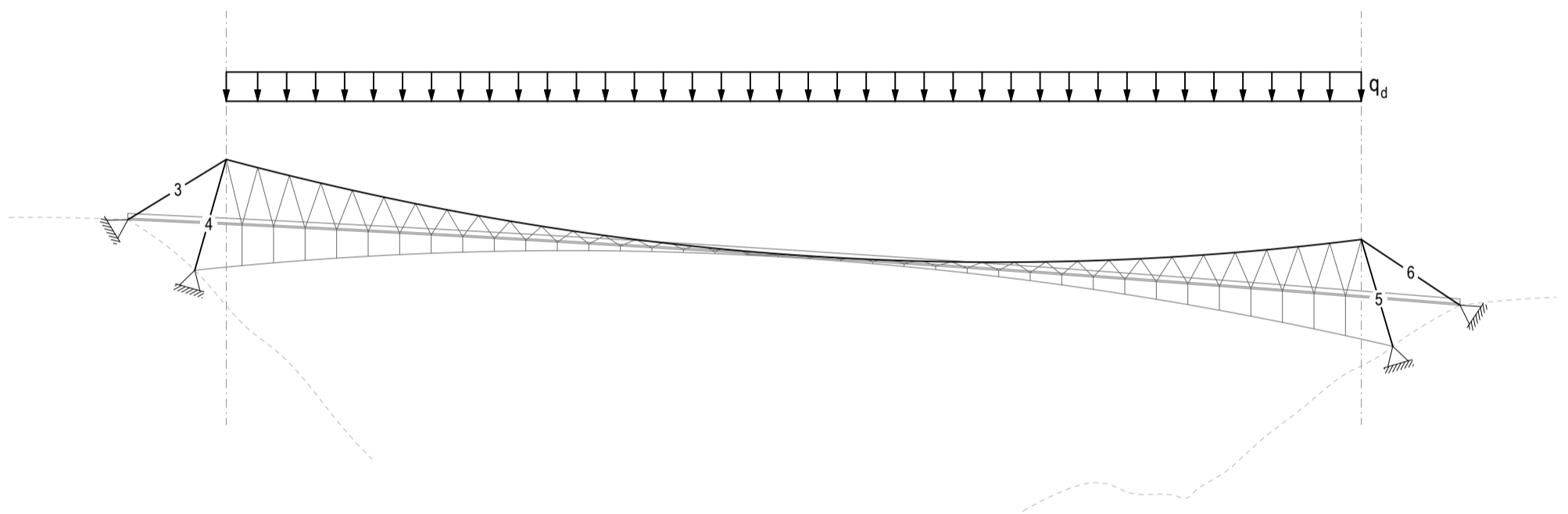

form diagram 1:1500

node I

node II

node III

subsystem

force diagram 1cm $\hat{=}$ 200kN

Task 8 Finding the thrust line using a trial funicular

- a) Four non-uniformly distributed point loads and the two supports A and B are given. Find the only possible structure that is in equilibrium under the given load and traverses point C.

First find the magnitude of the resultant R in the force diagram, then its position in the form diagram. To do this, use a trial funicular. Then find the reaction forces and the form of the arch going through point C. Finally, colour tension forces in red, compression forces in blue and the external forces in green.

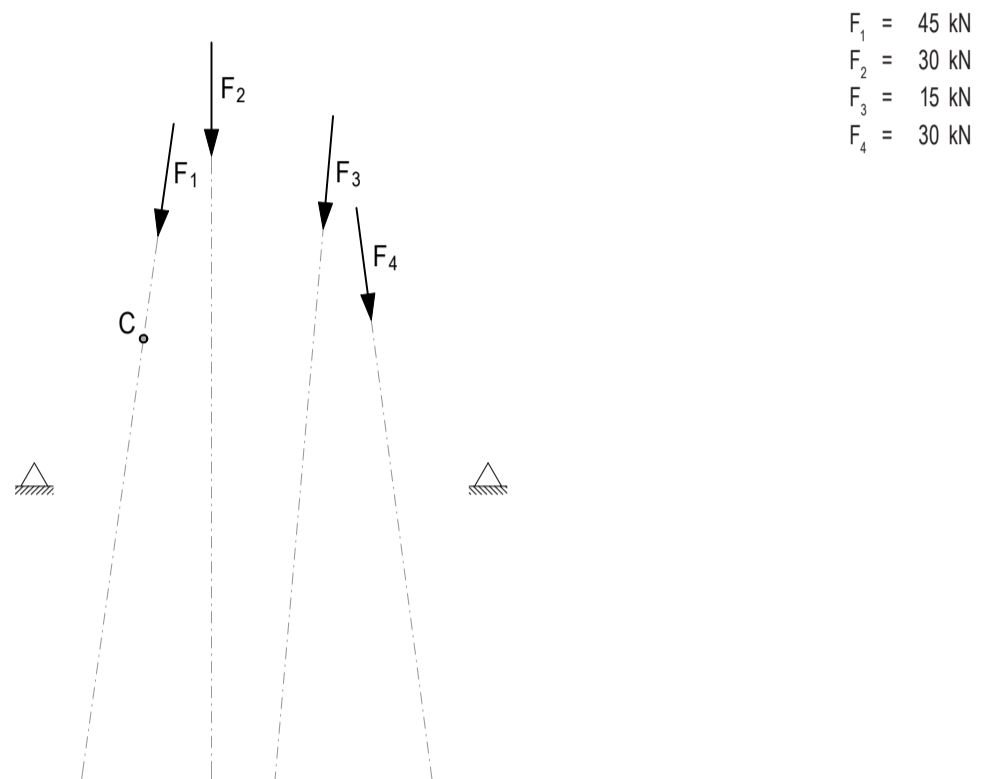

- $F_1 = 45 \text{ kN}$
- $F_2 = 30 \text{ kN}$
- $F_3 = 15 \text{ kN}$
- $F_4 = 30 \text{ kN}$

form diagram 1:250

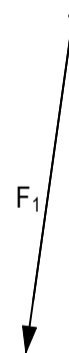

force diagram 1cm $\hat{=}$ 10kN

Task 9 Finding the thrust line

In a) and b), the thrust line that goes through points A, B and C is sought. Draw the corresponding force diagram for both situations. Colour tension forces in red, compression forces in blue and the external forces in green.

a)

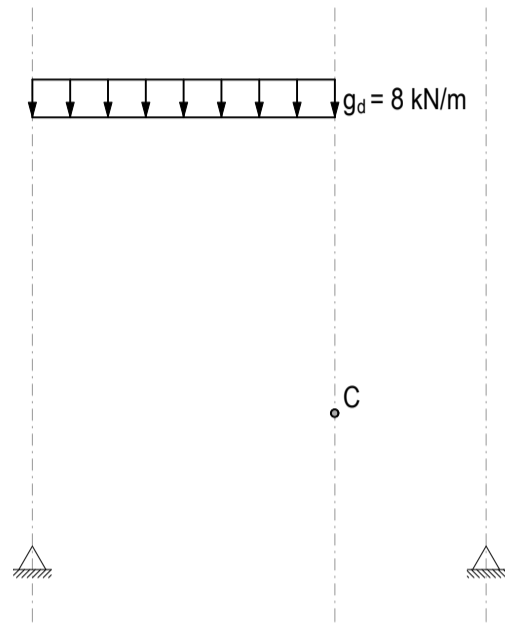

form diagram 1:250

force diagram 1cm ≙ 10kN

b)

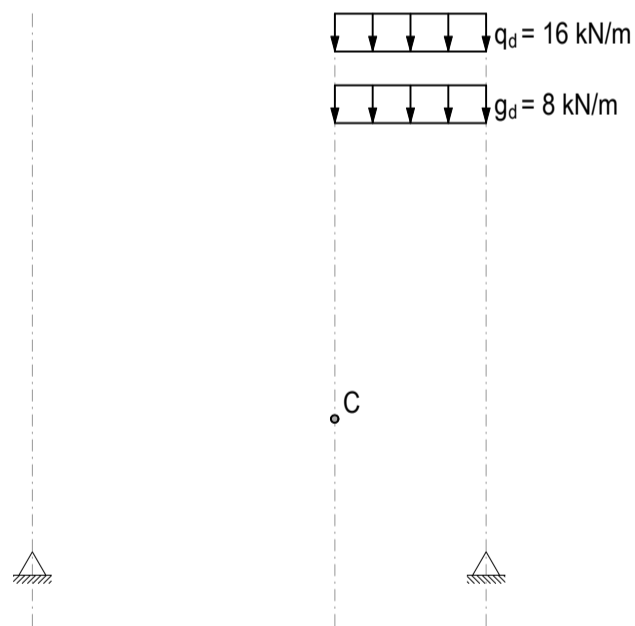

form diagram 1:250

force diagram 1cm ≙ 10kN

Task 10 Laon Cathedral, France

- Find a parabola going through points A and B which lies within the structure and carries the line load g_{1d} . Take into account that the applied force A from the nave acts horizontally.
- Then find the parabola through B, C and D. Find g_{2d} such that the supporting line from point B runs vertically into point E.
- In D, an additional point load F_{1d} is applied, representing the weight of the buttress. Determine F_{1d} such that the thrust line is running from point D into point F.
- Find the parabola through points E and F in such a way that the thrust line including the loads from the upper arches within the structure can be derived into the ground. From this, calculate the magnitude of the line load g_{3d} . Draw the corresponding force diagram and indicate the magnitudes of the reaction forces G and H. Colour tension forces in red, compression forces in blue and external forces in green.

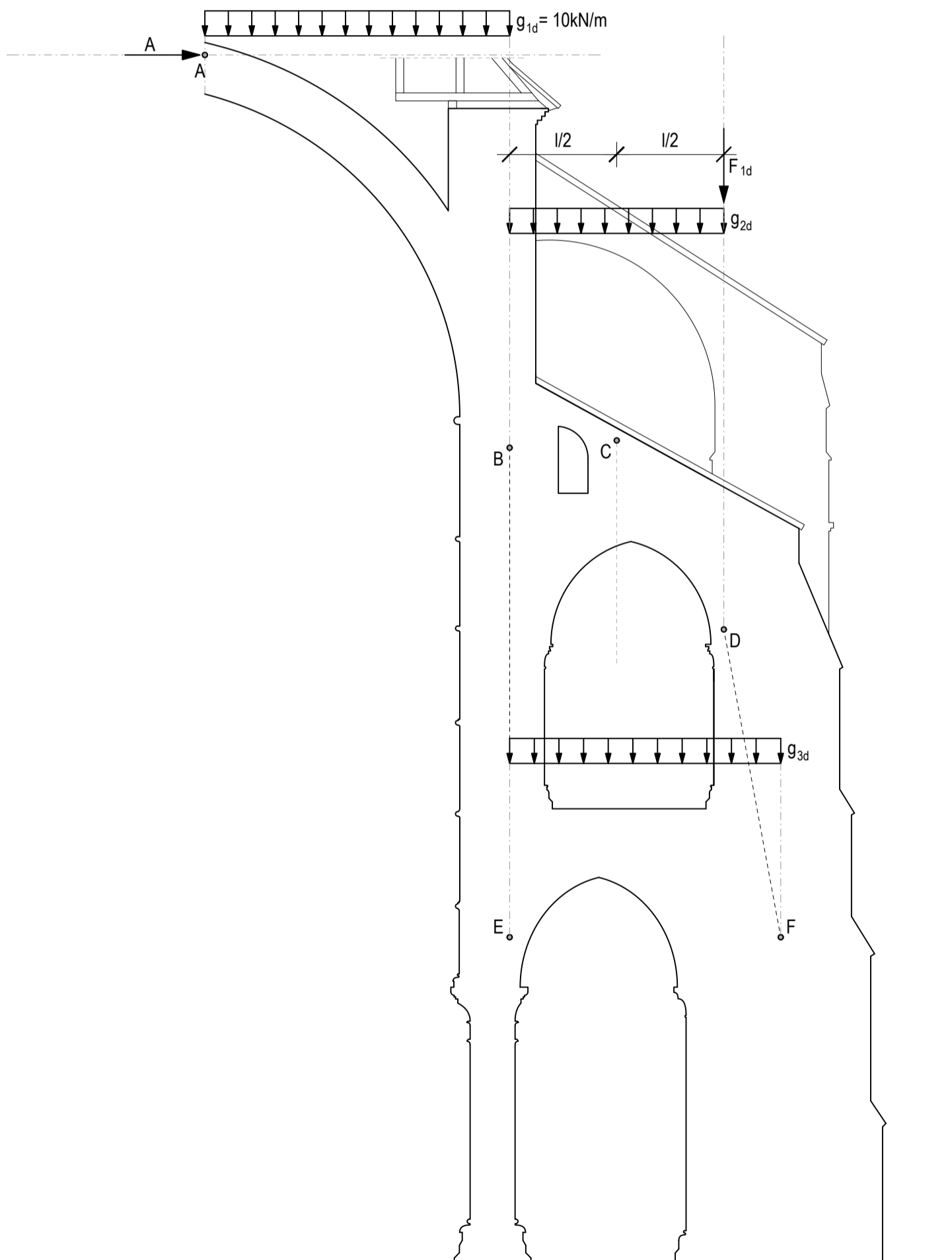

| G [kN] | H [kN] |
|-----------|-----------|
| | |

Task 11 Arch-cable-structure with different support conditions

Draw the force diagrams for the given cases. Pay attention to the support conditions. Determine the magnitude of A and B. Draw tension forces in red, compression forces in blue and reaction forces in green.

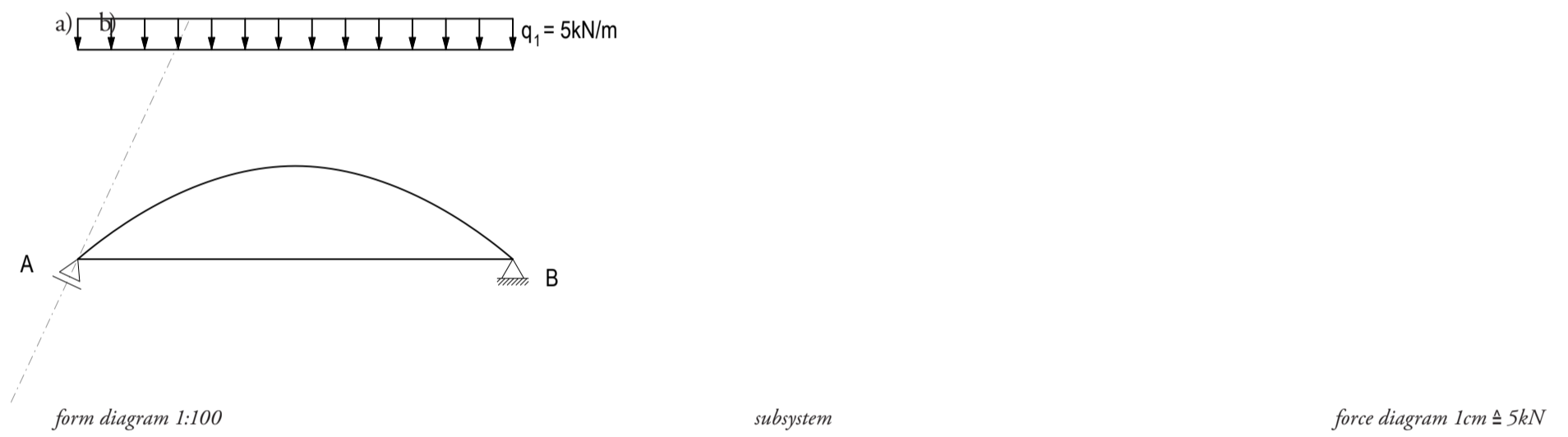
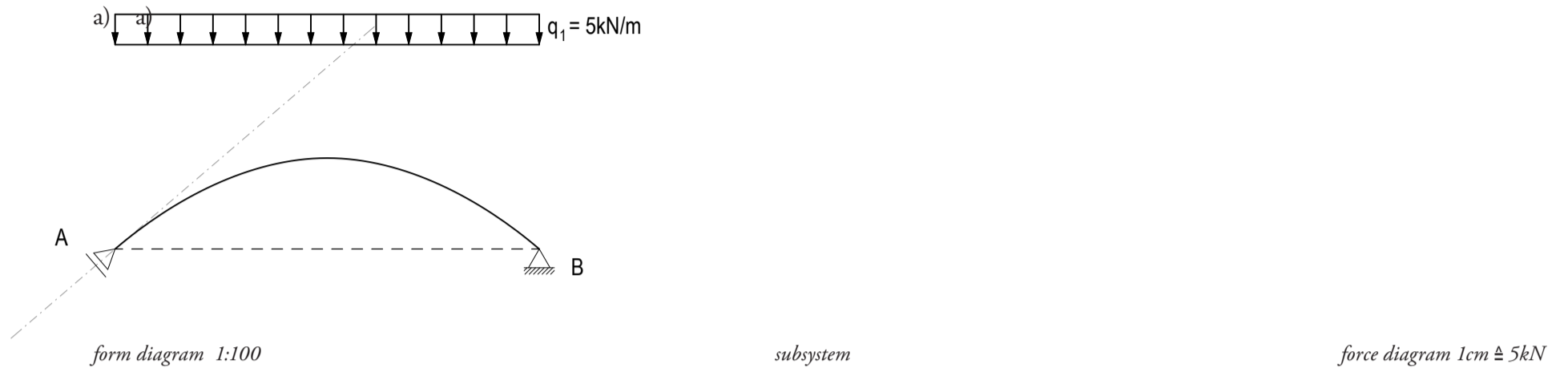

d) Design a solution in which the structure only spans underneath the closing string.



Task 12 From arch-cable to truss

Draw the corresponding force diagram for the given situations. Colour tension forces red, compression forces blue and the external forces green.

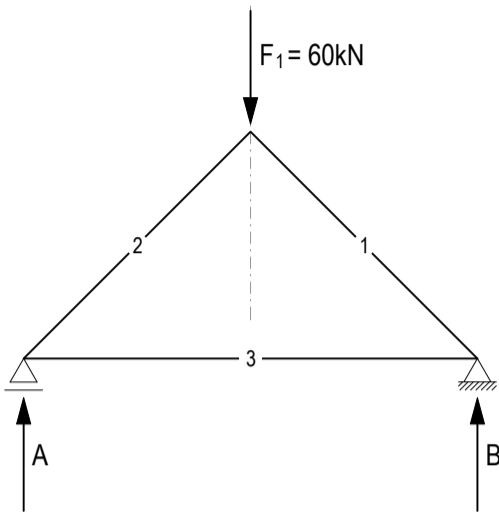

form diagram 1:100

subsystem

force diagram 1cm ≙ 10kN

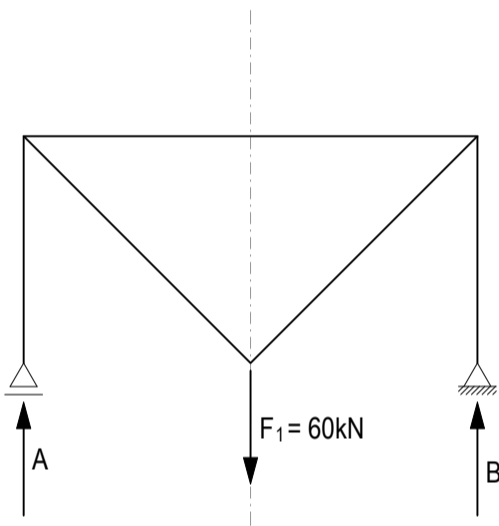

form diagram 1:100

subsystem

force diagram 1cm ≙ 10kN

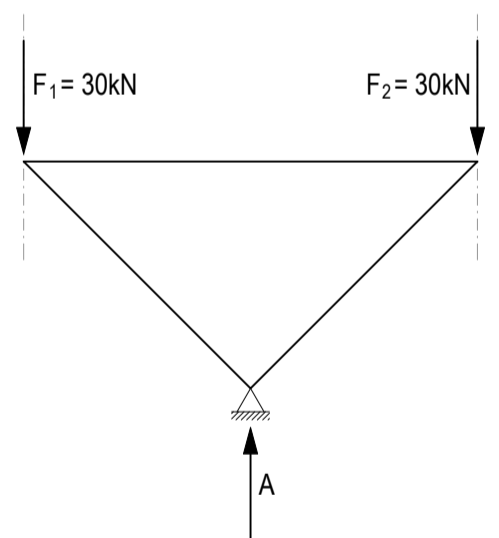

form diagram 1:100

subsystem

force diagram 1cm ≙ 10kN

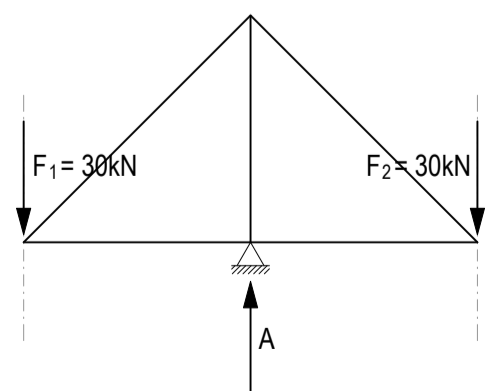

form diagram 1:100

subsystem

force diagram 1cm ≙ 10kN

Task 13 Bridge

- a) The form of the top chord of an arch-cable-structure for a bridge is given. Using the force diagram, find the form of the bottom chord for the given loading case. Note that the support B is a roller. Colour tension forces red, compression forces blue and the external forces green.
- b) The structure is to be modified such that the force in the bottom chord is constant. Describe in words how the form of the structure would change. Sketches in the position and force plan can help.

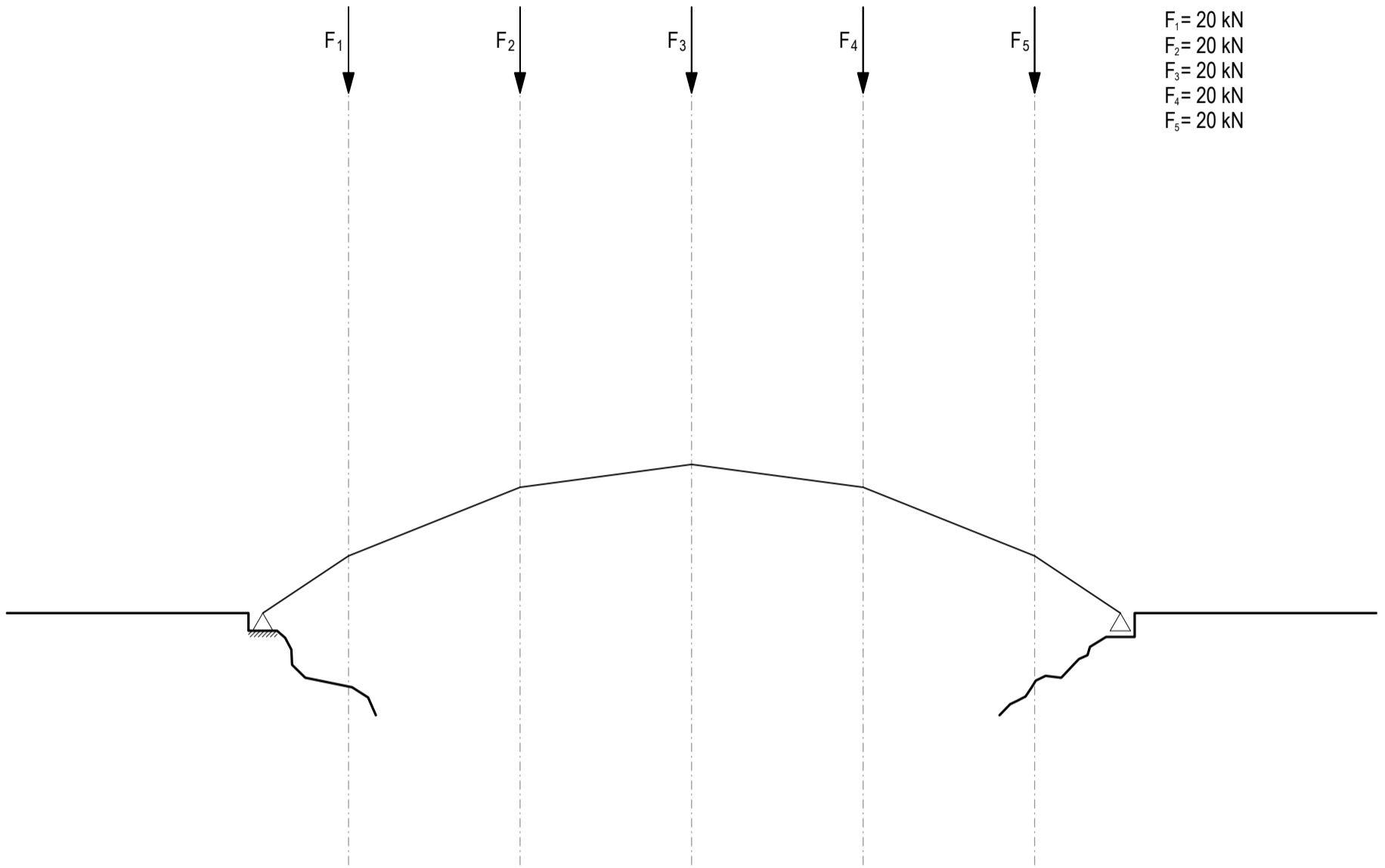

form diagram 1:100

force diagram 1cm ≙ 10kN

b)

Task 14.1 Span and cantilever

Design the form of a possible arch-cable structure for the given loading case with the means of graphic statics. Draw tension forces in red, compression forces in blue and reaction forces in green.

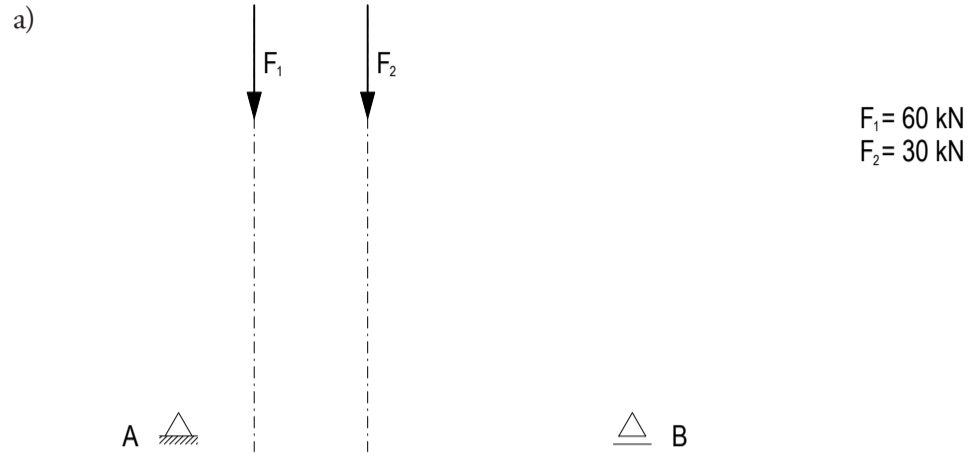

form diagram 1:100

force diagram 1cm ≙ 10kN



form diagram 1:100

force diagram 1cm ≙ 10kN

Task 14.2 Combination of two arch-cable structures

Transfer your geometry of your solutions from task 14.1 a) by superimposing the form diagrams of a) and b) into one arch-cable structure. Draw the corresponding force diagram. Indicate the direction of the support forces. Draw the tension forces in red, compression forces in blue and reaction forces in green.

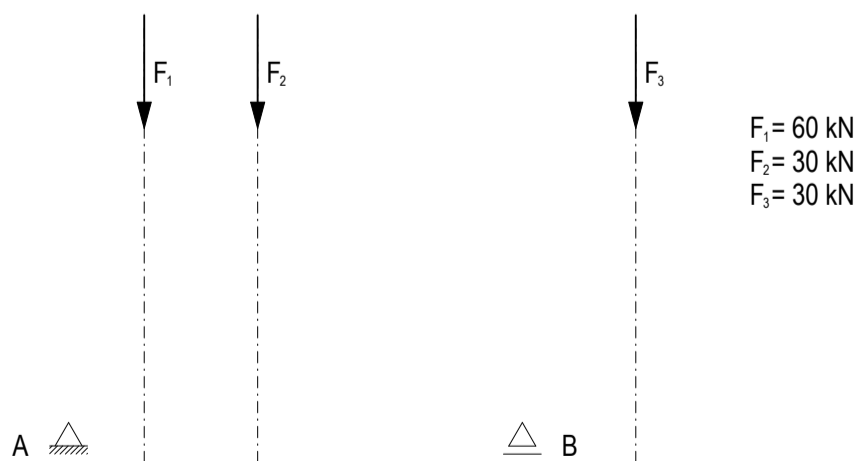

form diagram 1:100

force diagram 1cm ≙ 10kN

Task 15.1 Cantilever of an arch-cable structure

Design the cantilever of the arch-cable structure so that the horizontal force of the cantilever cancels out the horizontal force of the given arch. Draw the tension forces in red, compression forces in blue and reaction forces in green.

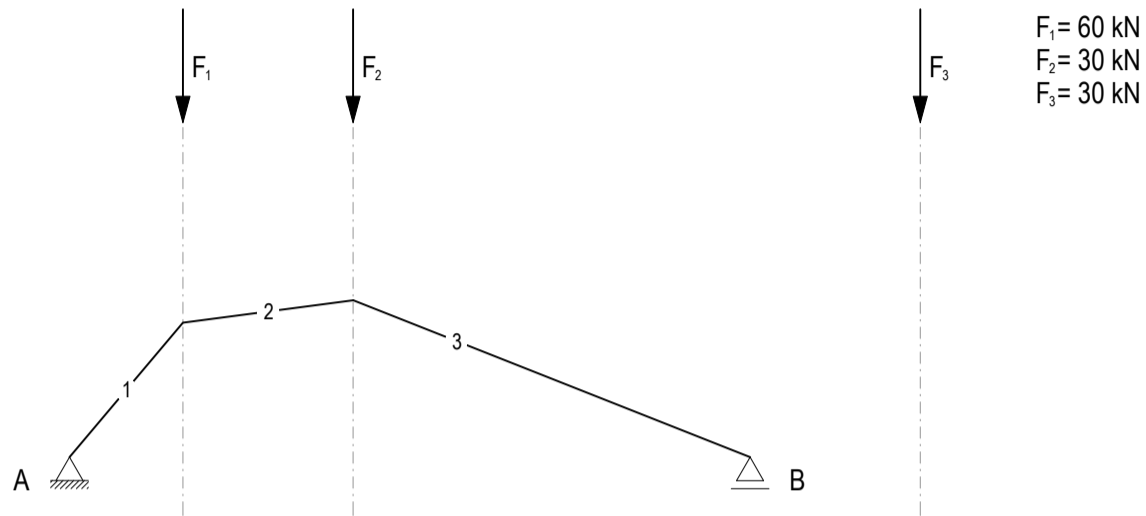

form diagram 1:100

force diagram 1cm ≙ 15kN

Task 15.2 Arch-cable structure

A fourth force is added to the loading case of the Task 15.1. Design the form of a possible arch-cable-structure for the given loading case with the means of graphic statics. Pay attention to the roller B where the horizontal forces have to cancel out. Draw tension forces in red, compression forces in blue and reaction forces in green.

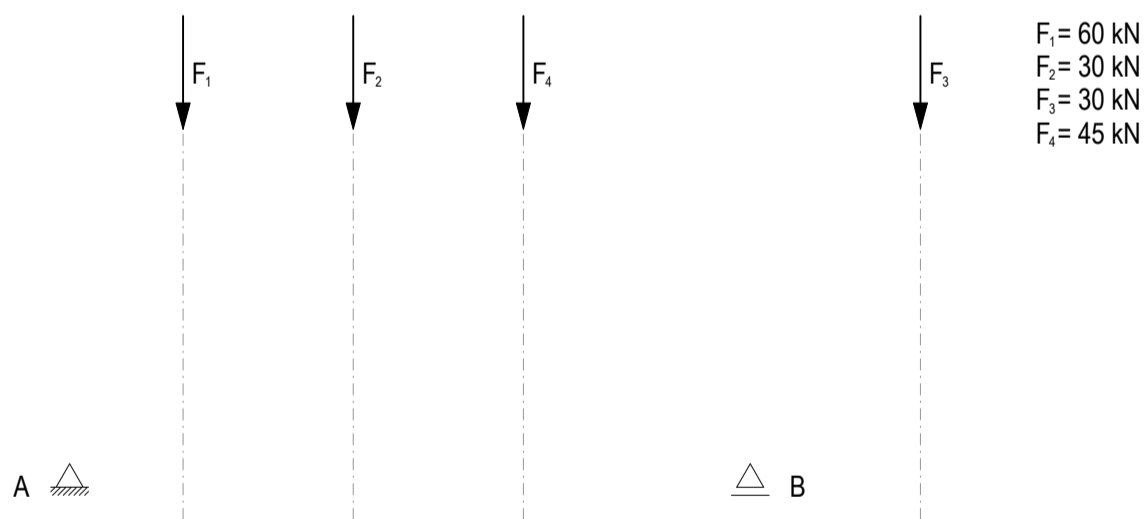

form diagram 1:100

force diagram 1cm ≙ 15kN